

# TIME LED®

## Elements Storm Batten 5ft 60W - Connect

### Installation and Operating Instructions



60W

7200  
LUMENS

3 YEARS  
WARRANTY

IP65

Please read and follow the instructions before operating your light and save this manual for future reference.

#### Package includes:

- 1 x Elements Storm Batten 5ft 60W - Connect
- 1 x Cable Gland
- 2 x Mounting Bracket
- 4 x Screws
- 4 x Wall Plugs
- 1 x Manual

#### Features:

- Equipped with rubber protection Gland and nylon cover protector
- Wiring specification: only use H07RN-2 x 1.0mm<sup>2</sup> (WARNING: Do Not Use PVC Cable)
- LED Lamp
- Class II Luminaire.

#### Safety:

- Electrical work, including installation and repair, must always be completed by a qualified technician.
- Disconnect the lamp from the mains supply and let the product cool down before you replace the light source.
- Never touch the light source when the lamp is turned on.
- In case of product failure, disconnect the lamp from the mains supply.
- The product is suitable for connecting through to multiple units up to a maximum of 500W.

INS-300967-V1

TIME LED is part of Pitacs Limited. For customer support contact:

Bradbourne Point, Bradbourne Drive, Tilbrook, Milton Keynes, Buckinghamshire MK7 8AT

T: +44 (0)1908 271155 F: +44 (0)1908 640017 E: info@TIMELED.co.uk W: www.TIMELED.co.uk



Product Code	300967
Size (mm)	1530x68x65
Lamp	SMD
Watts	60W
Lumens	7200lm
Lifespan	30,000 Hours
Beam Angle	120°

Colour Temp	5000K Daylight
Material	PC
Dimmable	No
Voltage/Hertz	170-265V 50Hz
Warranty	3 Years
IP Rating	IP65
Energy Rating	E

**Application:**

Suitable for use in:

- Outdoor and moisture exposed environments
- Indoors

**Installation:**

**Accessory Pack Includes**

- 1 x Cable Gland
- 2 x Mounting Bracket
- 4 x Screws
- 4 x Wall Plugs

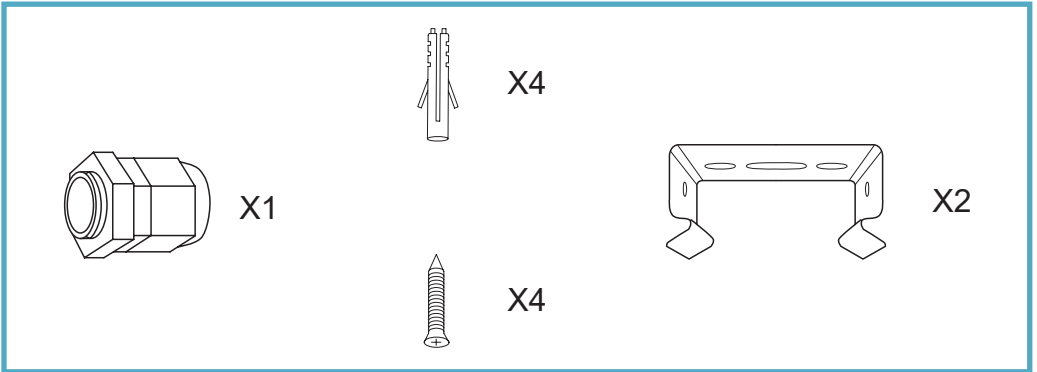

1) Affix mounting brackets in a suitable location and to a suitable surface.

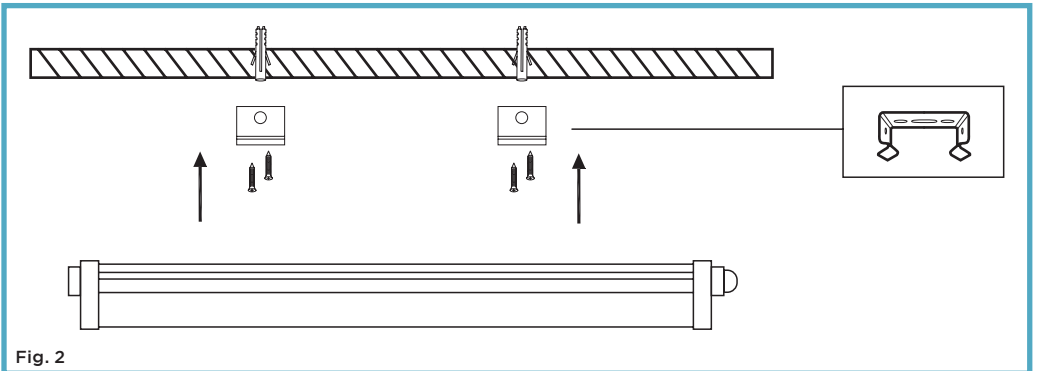

2) To connect the product:

- Twist the waterproof lock anti-clockwise and pull open the power connection carrier.
- Insert the power cable through the IP Gland.
- Lift the levers on the connectors and insert the live (brown) and neutral (blue) cable as shown.
- Tighten the IP Gland, re-insert the power connection carrier and tighten the waterproof lock clockwise.

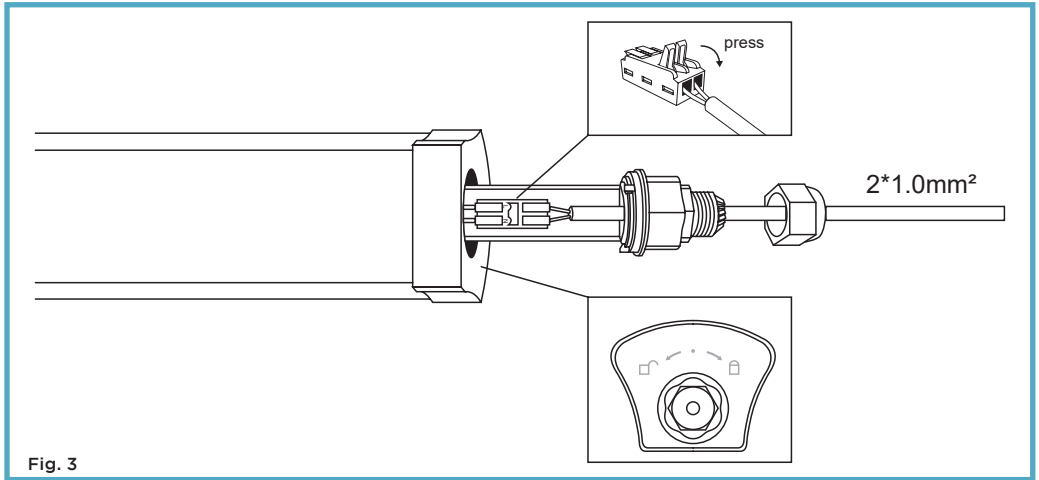

3) This product can be daisy-chained to a maximum of 500W.

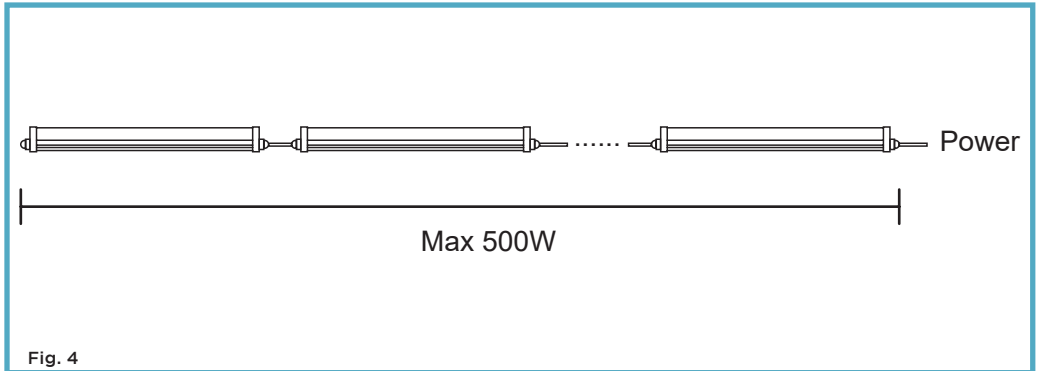

4) To daisy-chain the product:

- To access the output carrier, remove the plastic bung and screw in the supplied Cable Gland.
- Twist the waterproof lock anti-clockwise and pull open the power connection carrier.
- Insert the power cable through the IP Gland.
- Lift the levers on the connectors and insert the live (brown) and neutral (blue) cable as shown.
- Tighten the IP Gland, re-insert the power connection carrier and tighten the waterproof lock clockwise.

See Fig. 3.

**Cleaning:**

- Do not use any chemical or abrasive cleaners.
- Only clean the product with a soft dry cloth.

**Warning:**

- This product must be disconnected from the circuit if subjected to any high voltage or insulation resistance testing. Irreparable damage will occur if this instruction is not followed.

**Recycling Advice:**

- Electrical products should not be disposed of with household waste. Please check with your local authority or retailer for responsible recycling advice.

**Warranty:**

- This product is warranted to be free of defects in materials, design and workmanship for 3 years from the date of purchase (conditions apply, please see TIME LED website for further details). If a suspected fault should develop in this time, please contact us via the address below.

Full technical specification available upon request. Contact [info@TIMELED.co.uk](mailto:info@TIMELED.co.uk) for PDF.