

**Cleaning:**

- Do not use any chemical or abrasive cleaners.
- Clean product with only a soft dry cloth.

**Warranty:**

- This product is warranted to be free of defects in materials, design and workmanship for 3 years from the date of purchase (conditions apply, please see TIME LED website for further details). If a suspected fault should develop in this time, please contact us via the address on the front.

**Recycling Advice:**

Waste Electrical products should not be disposed of with household waste. Please recycle where facilities exist. Check with your local authority or retailer for recycling advice.

# TIME LED®

## Elements Storm Batten 6ft 75W - Connect

Installation and Operating Instructions

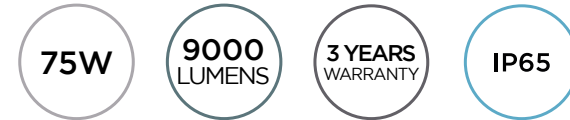

Read and follow instructions before operating your light.  
Save this manual for future reference.

**Package includes:**

- 1 x Elements Storm Batten 6ft 75W - Connect
- 1 x Cable Gland
- 2 x Mounting Bracket
- 4 x Screws
- 4 x Wall Plugs
- 1 x Manual

**Features:**

- Equipped with rubber protection Gland and nylon cover protector
- Wiring specification: only use H07RN-2 x 1.0mm<sup>2</sup> (WARNING: Do Not Use PVC Cable)
- LED Lamp
- Class II Luminaire.

**Safety:**

- Electrical work, including installation and repair, must always be completed by a qualified technician.
- Disconnect the lamp from the mains supply and let the product cool down before you replace the light source.
- Never touch the light source when the lamp is turned on.
- In case of product failure, disconnect the lamp from the mains supply.
- The product is suitable for connecting through to multiple units up to a maximum of 500W.

INS-303210-V1

Full Technical specification available upon request. Contact [info@timeled.co.uk](mailto:info@timeled.co.uk) for PDF.

# TIME LED®

**Elements Storm Batten  
6ft 75W - Connect**

**TIME LED is part of Pitacs Limited. For customer support contact:**

Bradbourne Point, Bradbourne Drive, Tilbrook, Milton Keynes, Buckinghamshire MK7 8AT

T: +44 (0)1908 271155 F: +44 (0)1908 640017 E: [info@timeled.co.uk](mailto:info@timeled.co.uk) W: [www.TIMELED.co.uk](http://www.TIMELED.co.uk)



<b>Product Code</b>	<b>303210</b>
Size (mm)	1830x68x65
Lamp	SMD
Watts	75W
Lumens	9000lm
Lifespan	30,000 Hours
Beam Angle	120°

Colour Temp	5000K Daylight
Material	PC
Dimmable	No
Voltage/Hertz	170-265V 50Hz
Warranty	3 Years
IP Rating	IP65
Energy Rating	E

**Application:**

Suitable for use in:

- Outdoor and moisture exposed environments
- Indoors

**Installation:**

**Accessory Pack Includes**

- |                 |                      |
|-----------------|----------------------|
| 1 x Cable Gland | 2 x Mounting Bracket |
| 4 x Screws      | 4 x Wall Plugs       |

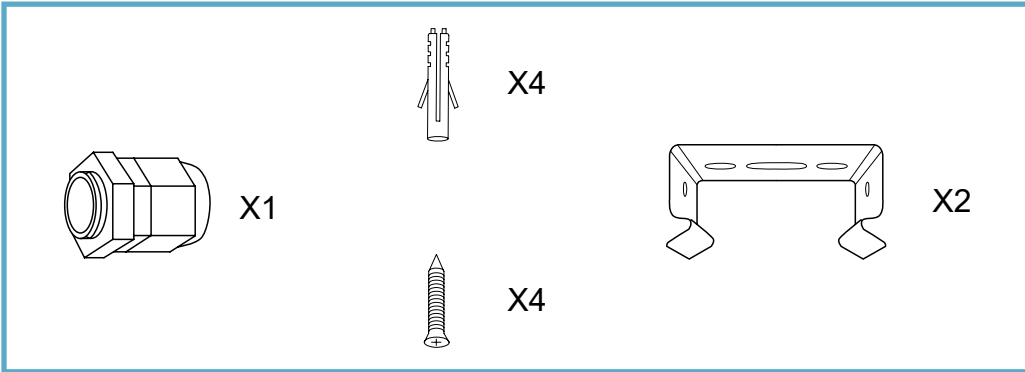

1) Affix mounting brackets in a suitable location and to a suitable surface.

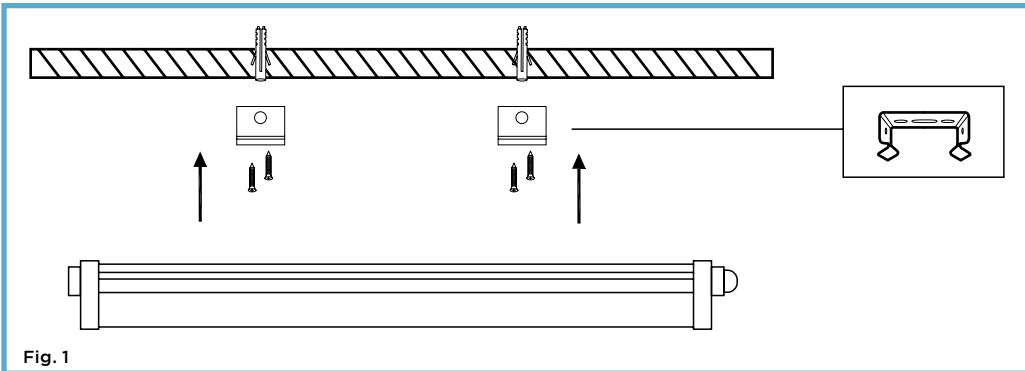

Fig. 1

2) To connect the product:

- Twist the waterproof lock anti-clockwise and pull open the power connection carrier.
- Insert the power cable through the IP Gland.
- Lift the levers on the connectors and insert the live (brown) and neutral (blue) cable as shown.
- Tighten the IP Gland, re-insert the power connection carrier and tighten the waterproof lock clockwise.

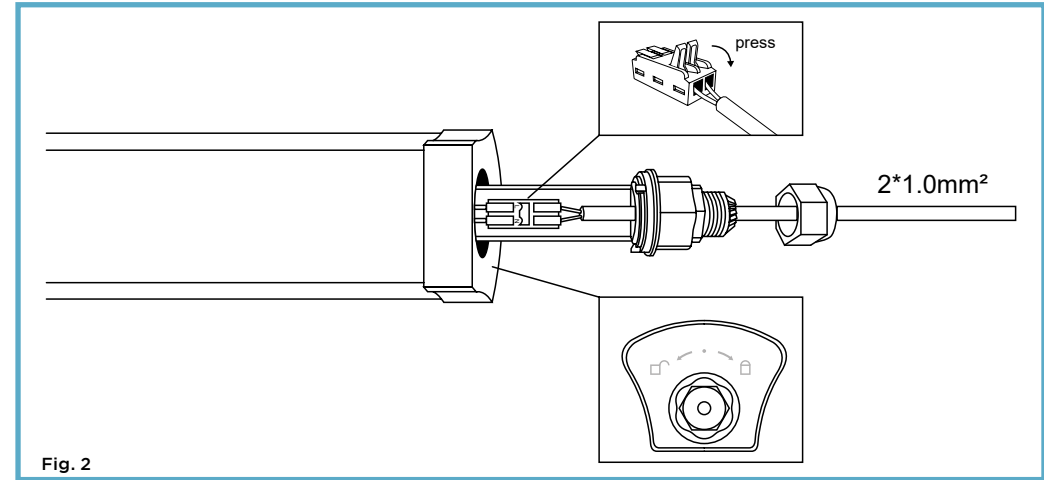

Fig. 2

3) This product can be daisy-chained to a maximum of 500W.

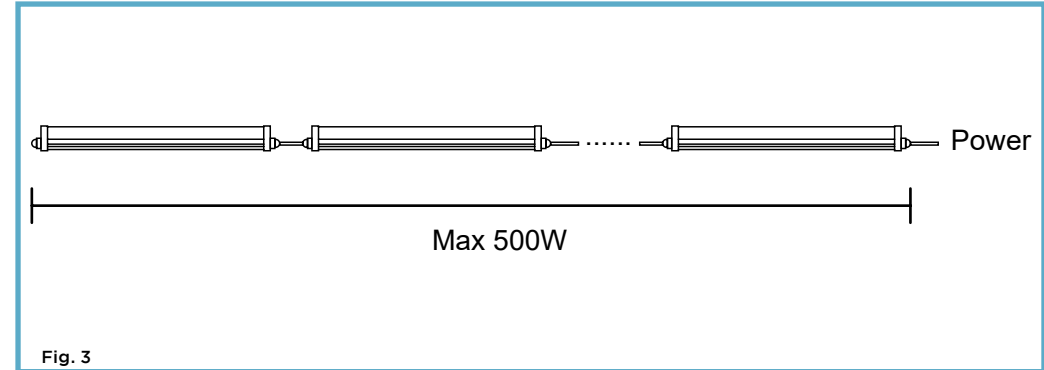

Fig. 3

4) To daisy-chain the product:

- To access the output carrier, remove the plastic bung and screw in the supplied Cable Gland.
- Twist the waterproof lock anti-clockwise and pull open the power connection carrier.
- Insert the power cable through the IP Gland.
- Lift the levers on the connectors and insert the live (brown) and neutral (blue) cable as shown.
- Tighten the IP Gland, re-insert the power connection carrier and tighten the waterproof lock clockwise.

See Fig. 2.